

## DONNEES TECHNIQUES

### Clapets à registre

poignée étoile carrée  
GN 6335.4 (DIN 6335) forme ST ou TE

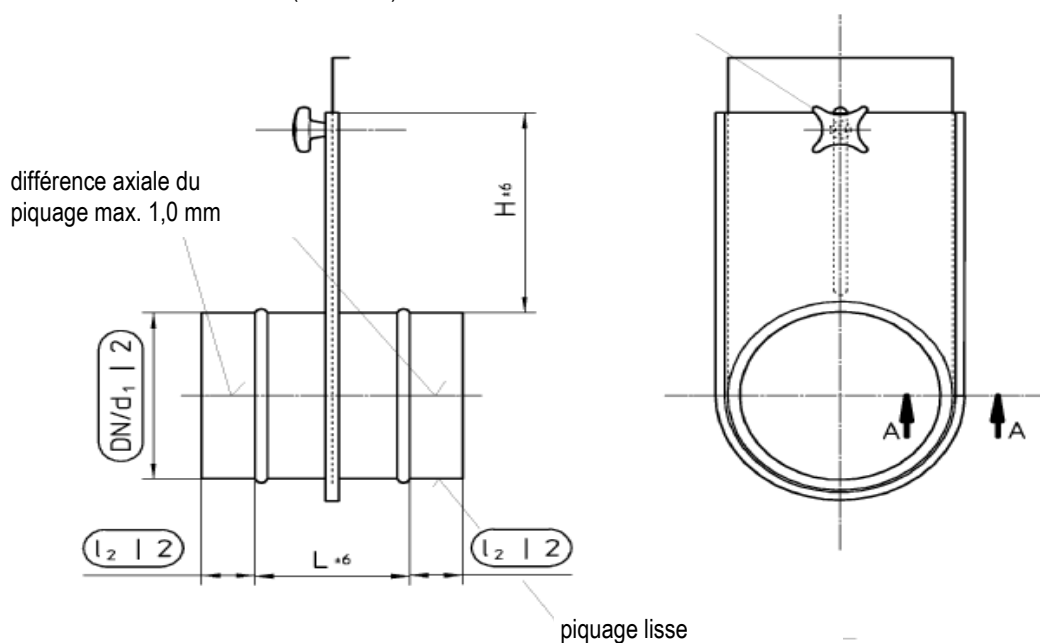

DN	L mm	H mm	Poids kg/pce
63	110	110	0.70
71	110	115	0.80
80	110	120	0.85
100	110	145	1.10
125	110	165	1.50
150	110	190	1.90
160	110	200	2.10
180	110	220	2.50
200	110	240	2.80
224	110	265	3.50
250	110	290	4.10
280	110	320	5.40
300	110	340	5.80
315	110	370	6.00
355	110	420	6.70
400	110	455	7.60
450	110	505	8.50
500	110	555	9.80